

## 19" Server-X Series Free Standing Indoor Rack Cabinet General Features

- VATPAN** Depending on the depth, your 19" devices can be positioned inside the 19" Server-X series free standing indoor rack cabinets.
- Server-X series free standing rack cabinets **12U, 16U, 18U, 20U, 22U, 26U, 30U, 32U, 34U, 36U, 38U, 42U, 45U, 47U** height and standard widths and depths **600x600mm, 600x800mm, 600x1000mm, (600x1100mm, 600x1200mm) 800x800mm, 800x1000mm, (800x1100mm,800x1200mm)** has dimensions.
- General features and dimensions **ISO 9001-2015, TS EN 61587-2018, TS EN 61587-2017, IEC 60917, IEC 60297, CE** produced in accordance with the standard.
- Optionally **Depth, width and height can be changed in special** projects.
- Standing type cabinets are produced in **IP20** protection classes as standard.
- Special multi-twist mainframe structure **1,5mm**, side covers **1,2mm** with its sheet-thick design, it is extremely resistant to impacts.



## 19" Server-X Series Free Standing Indoor Rack Cabinet Technical Specifications

- 19" Server-X Series Free Standing modular IT and Server Rack cabinet
- All steel construction
- Easy assembly and high efficiency thanks to ergonomic design
- Carrier frame is **1.50mm**, side covers are **1.20mm** thick steel construction
- Four-sided openable, lockable side and rear doors
- Adjustable rack mount uprights at the desired level
- Bottom, top and rear cable entry areas
- **400-800kg** carrying capacity
- 2, 4, 6 fan units that can be optionally mounted on the top
- Standard **80% perforated** front door with sheet metal frame support, rear flat door
- New generation lever locking mechanism
- Standard colors are Ral **9005**, **7035** and **7032**
- **50%** savings on shipping costs in disassembly, reasonable price



## 19" Server-X Series Free Standing Indoor Rack Cabinet General Features

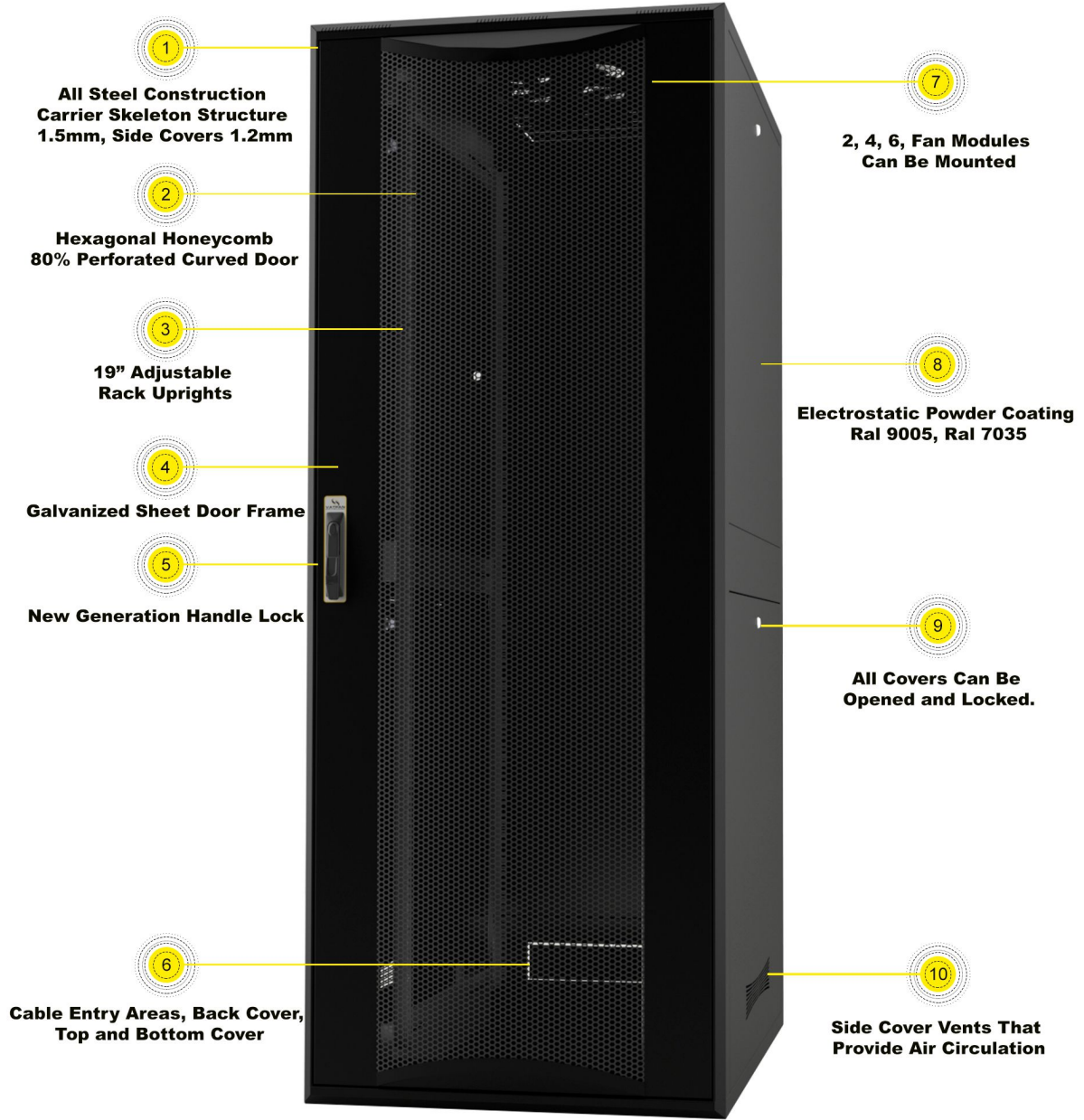

**Tempered Glass**

**1,2-1,5mm Steel**

**IP20 System**

**Quality Material**

**Access Security**

**Premium Quality**



## Server-X Series Cabin Door Structure and Dimension Technical Specifications

### COMPLETE SHEET PERFORATED DOORS

#### Server-X Serisi



FRONT VIEW

SIDE VIEW

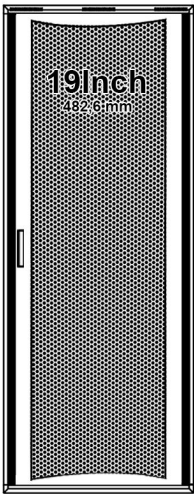

600mm  
800mm

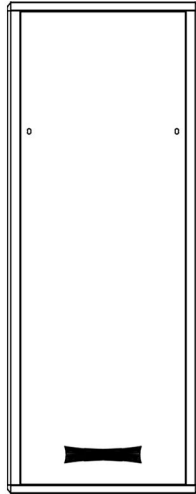

600mm  
800mm  
1000mm

( 1100mm  
1200mm  
Data Center )

### DOUBLE GLASS DOOR WITH ALUMINUM SIDE

#### Efficient Serisi Çift Kapılı

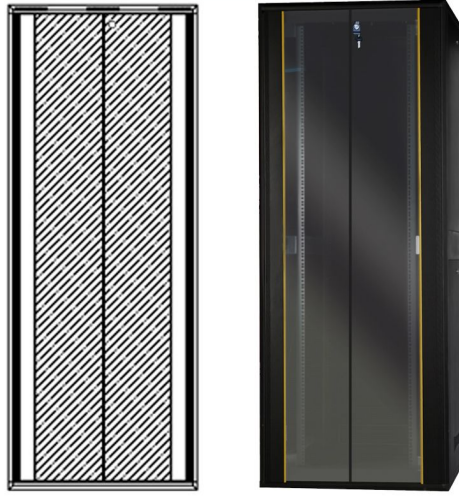

BACK VIEW

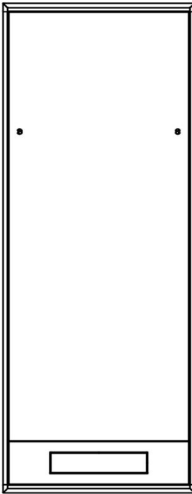

600mm  
800mm

### ALUMINUM EDGE GLASS DOOR

#### Efficient Serisi



- 47U-2180mm
- 45U-2180mm
- 42U-2040mm
- 38U-1780mm
- 36U-1780mm
- 34U-1510mm
- 32U-1510mm
- 30U-1510mm
- 26U-1330mm
- 22U-1150mm
- 20U-1150mm
- 16U-900mm
- 12U-710mm

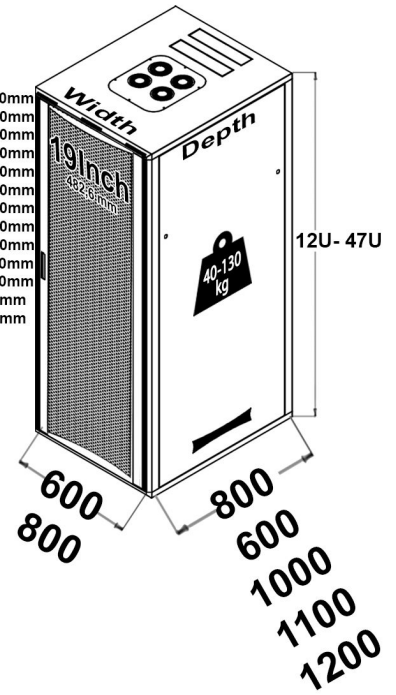

\*Dimensions are stated in mm (millimeters)



19" Server-X Series Free Standing Indoor Rack Cabinet Images

